

SOP4, DC Input Photo Transistor Coupler**Description**

The TWS357 series combine an AlGaAs infrared emitting diode as the emitter which is optically coupled to a silicon planar phototransistor detector in a plastic SOP4 package.

With the robust coplanar double mold structure, TWS357 series provide the most stable isolation feature.

Features

- High isolation 3750 VRMS
- CTR flexibility available see order information
- DC input with transistor output
- Operating temperature range - 55 °C to 110 °C
- REACH compliance
- Halogen free
- MSL class 1

Applications

- Switch mode power supplies
- Programmable controllers
- Household appliances
- Office equipment

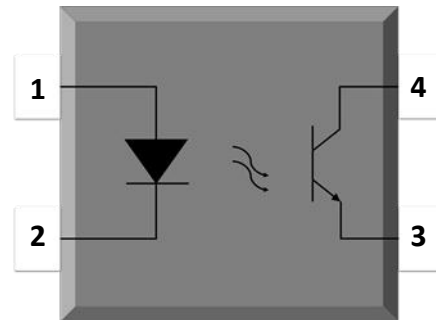
SCHEMATIC**PIN DEFINITION**

1. Anode
2. Cathode
3. Emitter
4. Collector

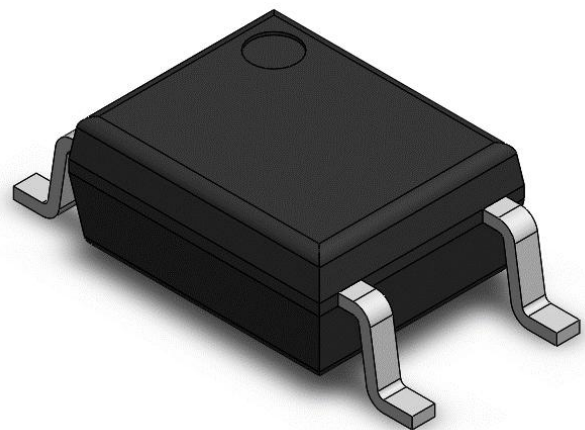
PACKAGE OUTLINE

SOP4, DC Input Photo Transistor Coupler**ABSOLUTE MAXIMUM RATINGS**

PARAMETER	SYMBOL	VALUE	UNIT	NOTE
INPUT				
Forward Current	I_F	60	mA	
Peak Forward Current	I_{FP}	1	A	1
Reverse Voltage	V_R	6	V	
Input Power Dissipation	P_I	100	mW	
OUTPUT				
Collector - Emitter Voltage	V_{CEO}	35	V	
Emitter - Collector Voltage	V_{ECO}	7	V	
Collector Current	I_C	50	mA	
Output Power Dissipation	P_O	150	mW	
COMMON				
Total Power Dissipation	P_{tot}	200	mW	
Isolation Voltage	V_{iso}	3750	V _{rms}	2
Operating Temperature	T_{opr}	-55~110	°C	
Storage Temperature	T_{stg}	-55~125	°C	
Soldering Temperature	T_{sol}	260	°C	

Note 1. 100μs pulse, 100Hz frequency

Note 2. AC For 1 Minute, R.H. = 40 ~ 60%

SOP4, DC Input Photo Transistor Coupler

ELECTRICAL OPTICAL CHARACTERISTICS at Ta=25°C							
PARAMETER	SYMBOL	MIN	TYP.	MAX.	UNIT	TEST CONDITION	NOTE
INPUT							
Forward Voltage	V _F	-	1.24	1.4	V	IF=10mA	
Reverse Current	I _R	-	-	10	μA	VR=6V	
Input Capacitance	C _{in}	-	10	-	pF	V=0, f=1kHz	
OUTPUT							
Collector Dark Current	I _{CEO}	-	-	100	nA	VCE=20V, IF=0	
Collector-Emitter Breakdown Voltage	BV _{CEO}	35	-	-	V	IC=0.1mA, IF=0	
Emitter-Collector Breakdown Voltage	BV _{ECO}	7	-	-	V	IE=0.1mA, IF=0	
TRANSFER CHARACTERISTICS							
Current Transfer Ratio	TWS357	CTR	50	-	600	%	IF=5mA, VCE=5V
	TWS357A		80	-	160		
	TWS357B		130	-	260		
	TWS357C		200	-	400		
Collector-Emitter Saturation Voltage	V _{CE(sat)}	-	0.06	0.2	V	IF=20mA, IC=1mA	
Isolation Resistance	R _{ISO}	10 ¹²	10 ¹⁴	-	Ω	DC500V, 40 ~ 60% R.H.	
Floating Capacitance	C _{IO}	-	0.4	1	pF	V=0, f=1MHz	
Cut-off Frequency	f _c	-	80	-	kHz	VCE=2V, IC=2mA RL=100Ω, -3dB	4
Response Time (Rise)	t _r	-	3	18	μs	VCE=2V, IC=2mA	3
Response Time (Fall)	t _f	-	4	18	μs	RL=100Ω	3

Note 3. Fig.12&13

Note 4. Fig.14

SOP4, DC Input Photo Transistor Coupler

CHARACTERISTIC CURVES

Fig.1 Forward Current vs. Ambient Temperature

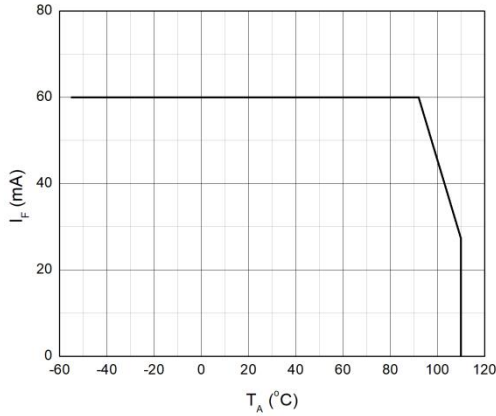

Fig.2 Collector Power Dissipation vs. Ambient Temperature

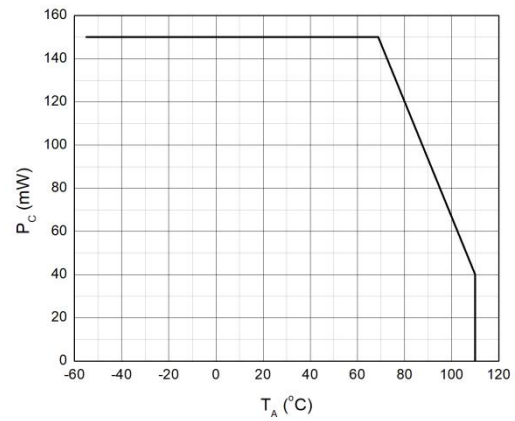

Fig.3 Forward Current vs. Forward Voltage

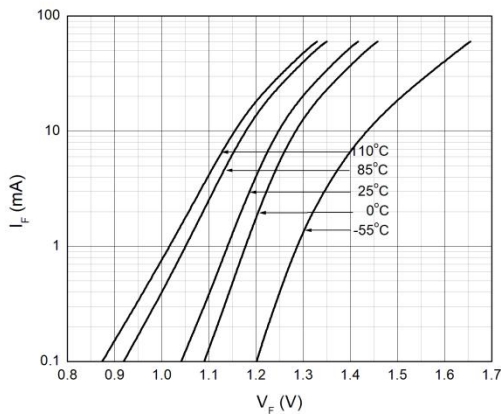

Fig.4 Collector Dark Current vs. Ambient Temperature

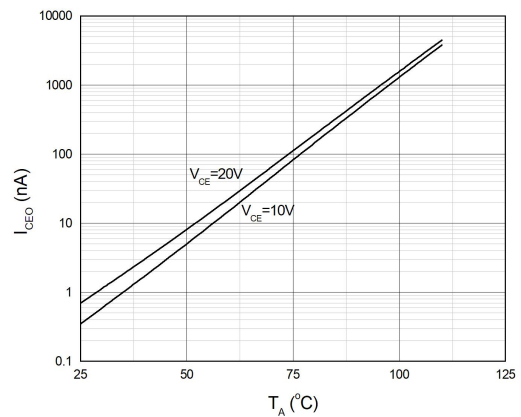
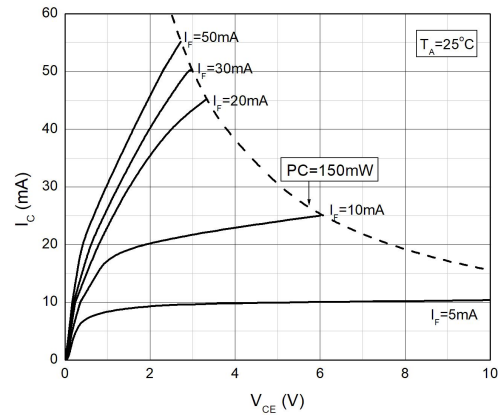
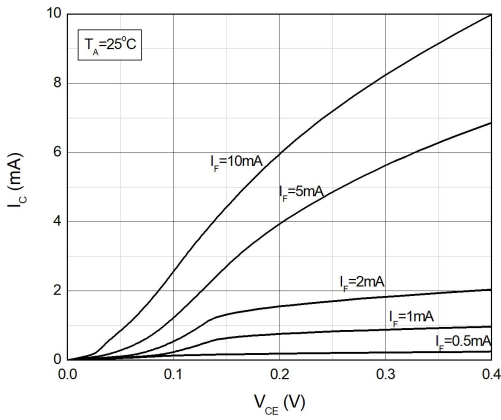

Fig.5 Collector Current vs. Collector-emitter Voltage

Fig.6 Collector Current vs. Collector-emitter Voltage

SOP4, DC Input Photo Transistor Coupler



CHARACTERISTIC CURVES

Fig.7 Normalized Current Transfer Ratio vs. Forward Current

Fig.8 Normalized Current Transfer Ratio vs. Ambient Temperature

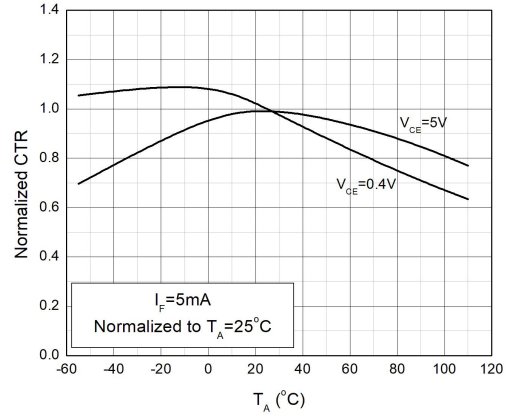
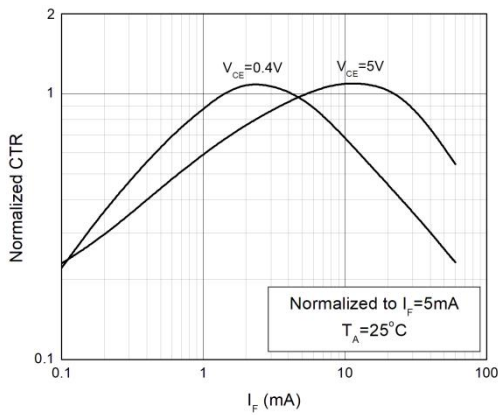

Fig.9 Collector-emitter Saturation Voltage vs. Ambient Temperature

Fig.10 Switching Time vs. Load Resistance

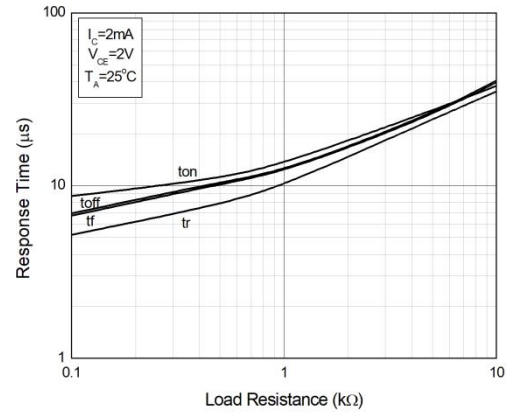
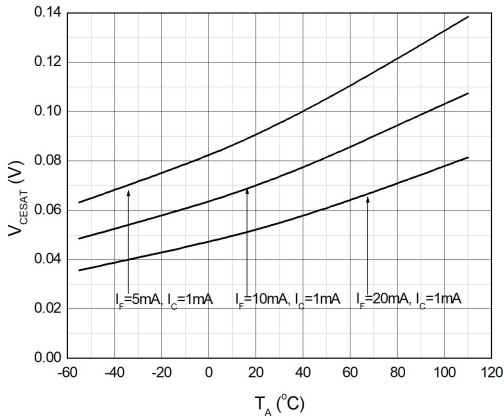
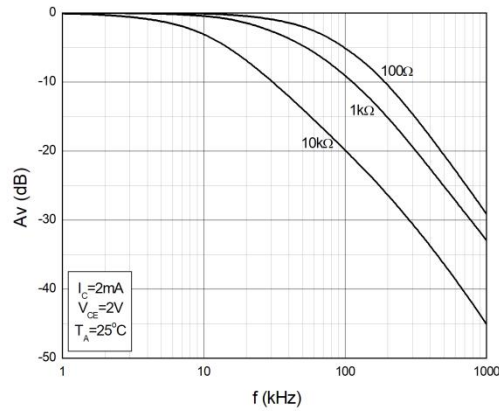

Fig.11 Frequency Response

SOP4, DC Input Photo Transistor Coupler



TEST CIRCUITS

Fig.12 Test Circuits of Response Time

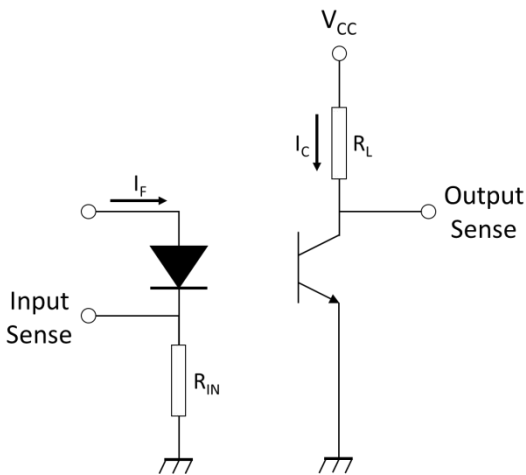

Fig.13 Curves of Response Time

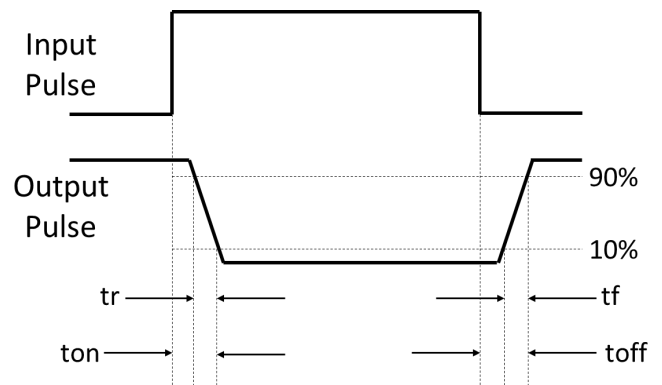
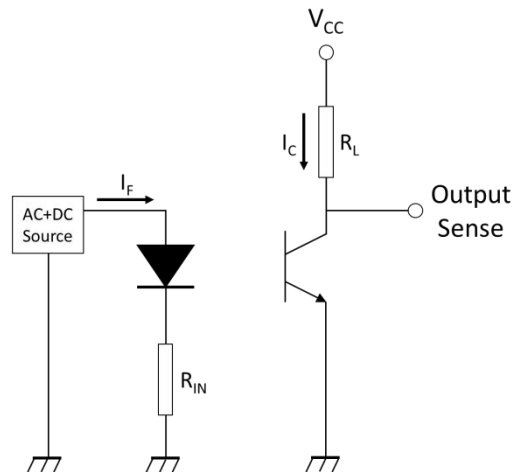

Fig.14 Test Circuits of Frequency Response



SOP4, DC Input Photo Transistor Coupler

SOP4, DC Input Photo Transistor Coupler

PACKAGE DIMENSIONS (Dimensions in mm unless otherwise stated)

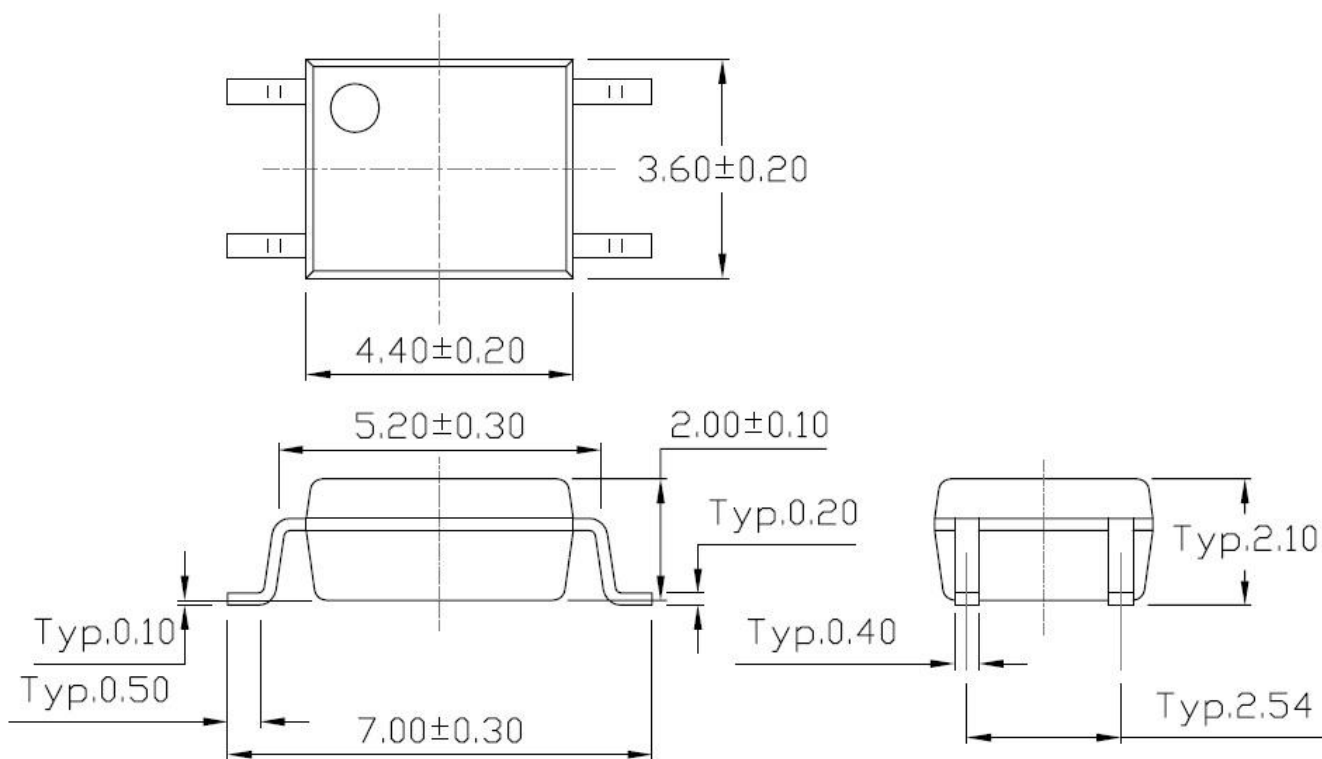

Recommended Solder Mask (Dimensions in mm unless otherwise stated)

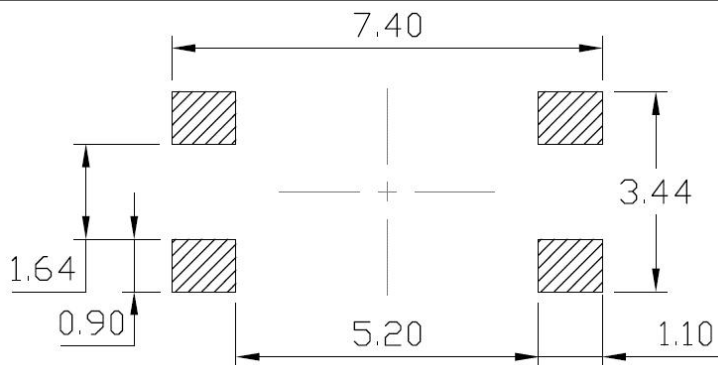

SOP4, DC Input Photo Transistor Coupler

CARRIER TAPE SPECIFICATIONS (Dimensions in mm unless otherwise stated)

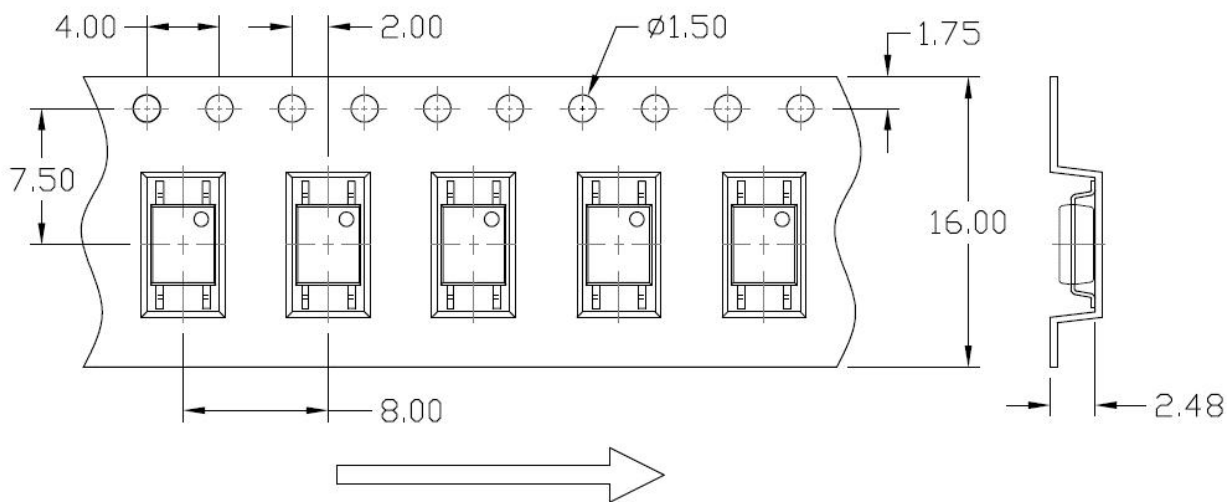

SOP4, DC Input Photo Transistor Coupler

REEL SPECIFICATIONS (Dimensions in mm unless otherwise stated)

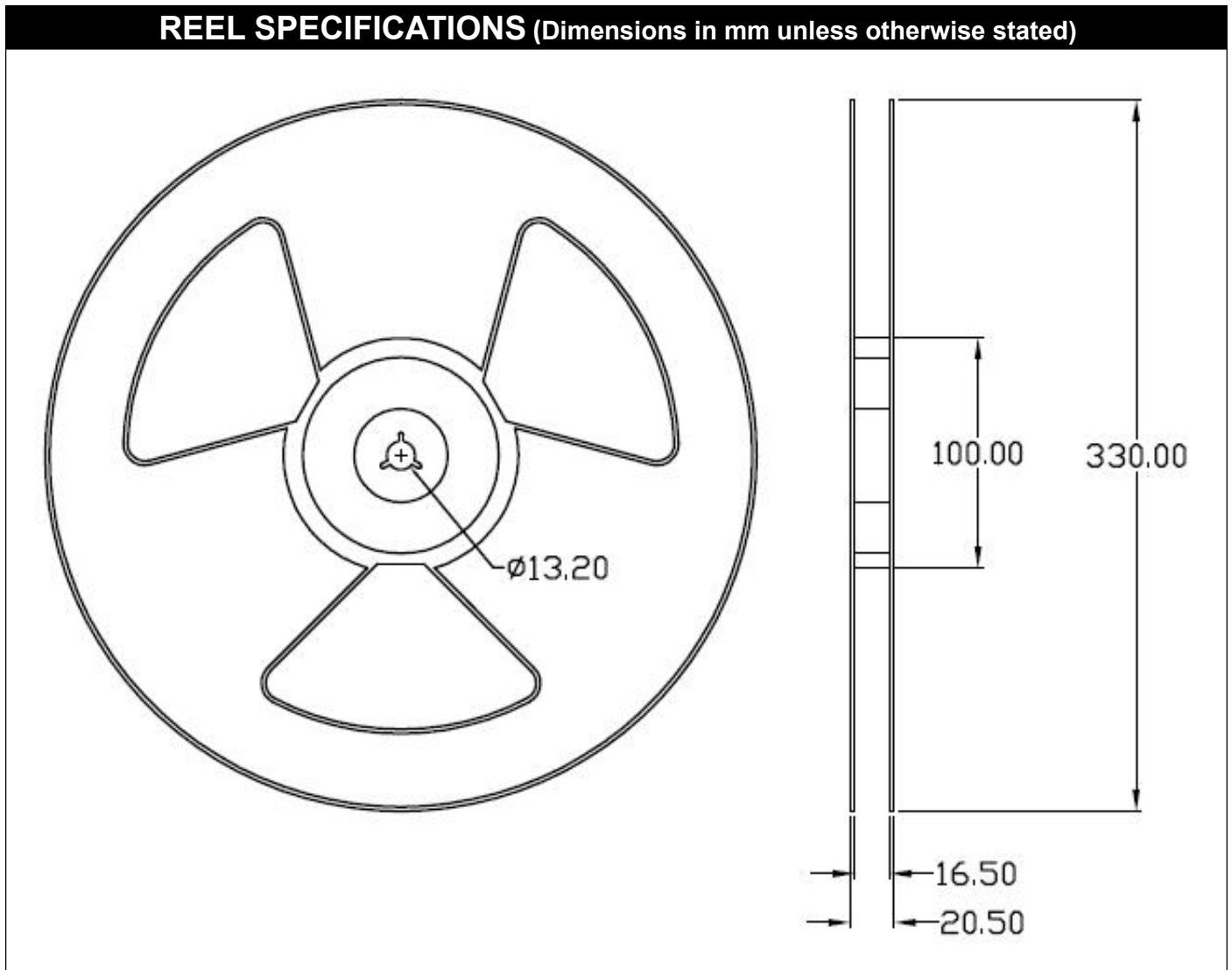

SOP4, DC Input Photo Transistor Coupler

BOX SPECIFICATIONS (Reel Type)

Inner Box



- L x W x H = 36cm x 36cm x 6.9cm

Outer Box

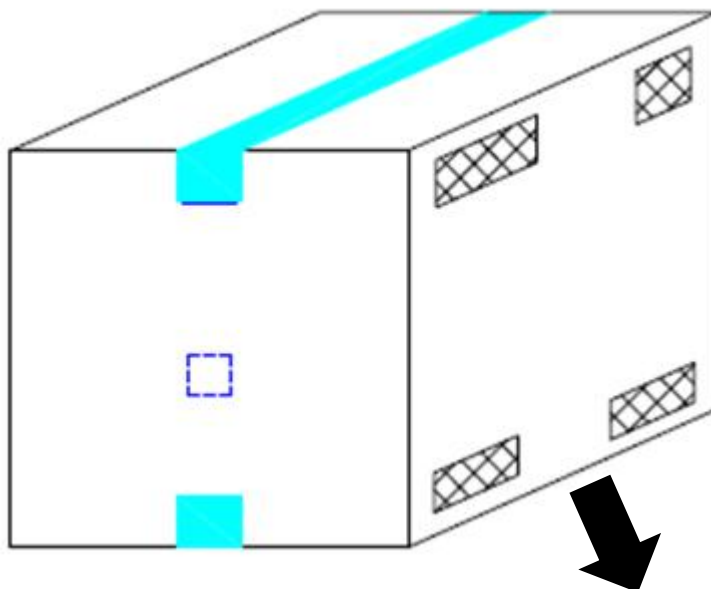

- L x W x H = 45cm x 38cm x 38cm

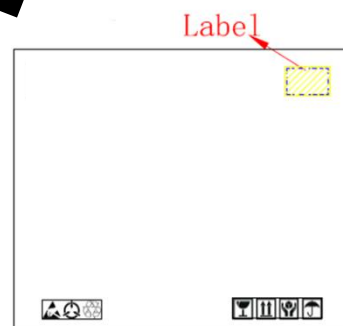

SOP4, DC Input Photo Transistor Coupler

ORDERING AND MARKING INFORMATION

MARKING INFORMATION

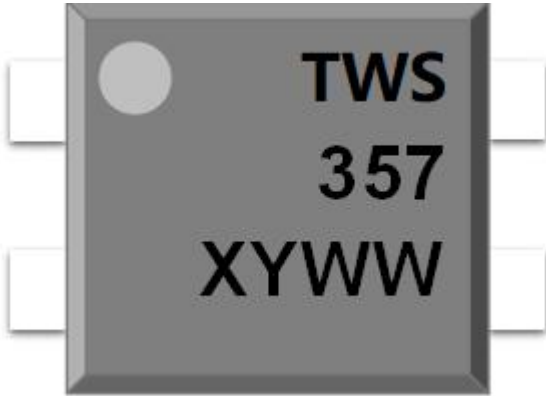

TWS : Company Abbr.
 357 : Part Number
 X : CTR Rank
 Y : Fiscal Year
 WW : Work Week

ORDERING INFORMATION

LABEL INFORMATION

TWS357X1(Z)-G

TWS – Company Abbr.
 357 – Part Number
 X – Rank (A/B/C or None)



PACKING QUANTITY

Option	Quantity	Quantity – Inner box	Quantity – Outer box
T1	3000 Units/Reel	3 Reels/Inner box	5 Inner box/Outer box = 45k Units

SOP4, DC Input Photo Transistor Coupler

REFLOW INFORMATION

REFLOW PROFILE

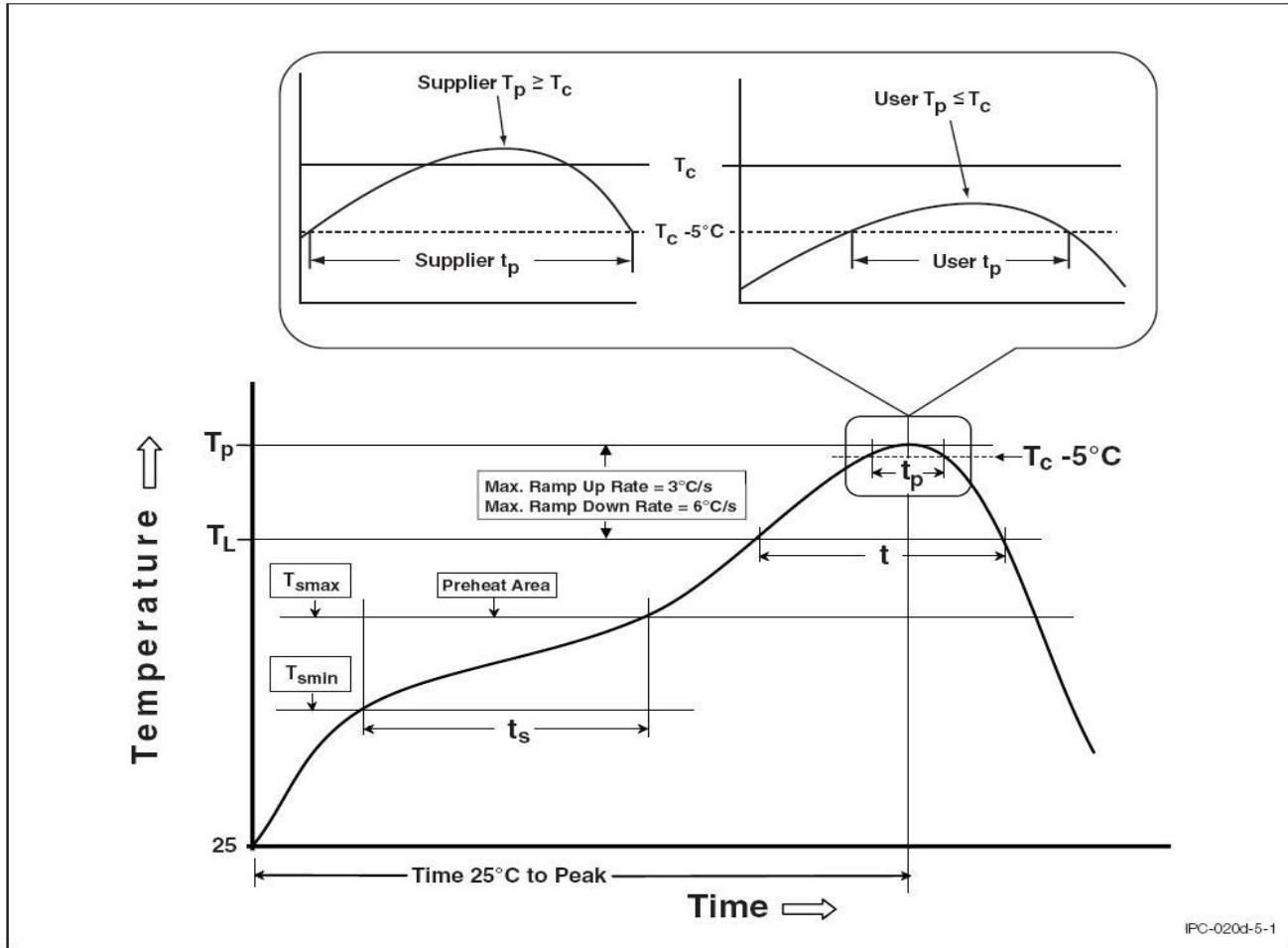

Profile Feature	Sn-Pb Assembly Profile	Pb-Free Assembly Profile
Temperature Min. (Tsmmin)	100	150°C
Temperature Max. (Tsmmax)	150	200°C
Time (ts) from (Tsmmin to Tsmmax)	60-120 seconds	60-120 seconds
Ramp-up Rate (tL to tP)	3°C/second max.	3°C/second max.
Liquidous Temperature (TL)	183°C	217°C
Time (tL) Maintained Above (TL)	60 – 150 seconds	60 – 150 seconds
Peak Body Package Temperature	235°C +0°C / -5°C	260°C +0°C / -5°C
Time (tP) within 5°C of 260°C	20 seconds	30 seconds
Ramp-down Rate (TP to TL)	6°C/second max	6°C/second max
Time 25°C to Peak Temperature	6 minutes max.	8 minutes max.